white's

**COINMASTER
CLASSIC II
COINMASTER**

Manufactured by White's Electronics, Inc., Sweet Home, Oregon U.S.A.

Instruction Manual

ATTENTION:

To use your Classic II in average conditions, set DISC Control to RING RANGE P, SENS Control to P, and Toggle Switch to the DISC position.

The loop must be in continuous motion (moving from side-to-side) in order for this model to respond to metal.

Good metals produce smooth solid beeps, junk metals produce clicks or sputter-sounding beeps.

Pinpoint metals exact location by placing the Toggle in Lock position while holding loop near ground, then "X" loop over area. Loudest beep indicates target center. Place Toggle back to DISC position before continuing.

For more detailed operation instructions, refer to the information inside this manual.

**Handleiding beschikbaar gesteld door MidHolland detectoren.
(www.detector.nl)**

Index

Assembly	3-4
Batteries.....	5-6
Operating Instructions.....	7-8
Explanation of Controls.....	9-12
On/Off Sens (Sensitivity).....	9
DI SC (Discrimination).....	10
Toggle Switch	11
Headphones	12
Search Methods.....	13
Proper Care of your Detector.....	14-15
Advanced Operators.....	16-17
Glossary of Terms	18-19
Warranty	20

Assembly Instructions

Remove all parts from the shipping carton, and make sure you have the following:

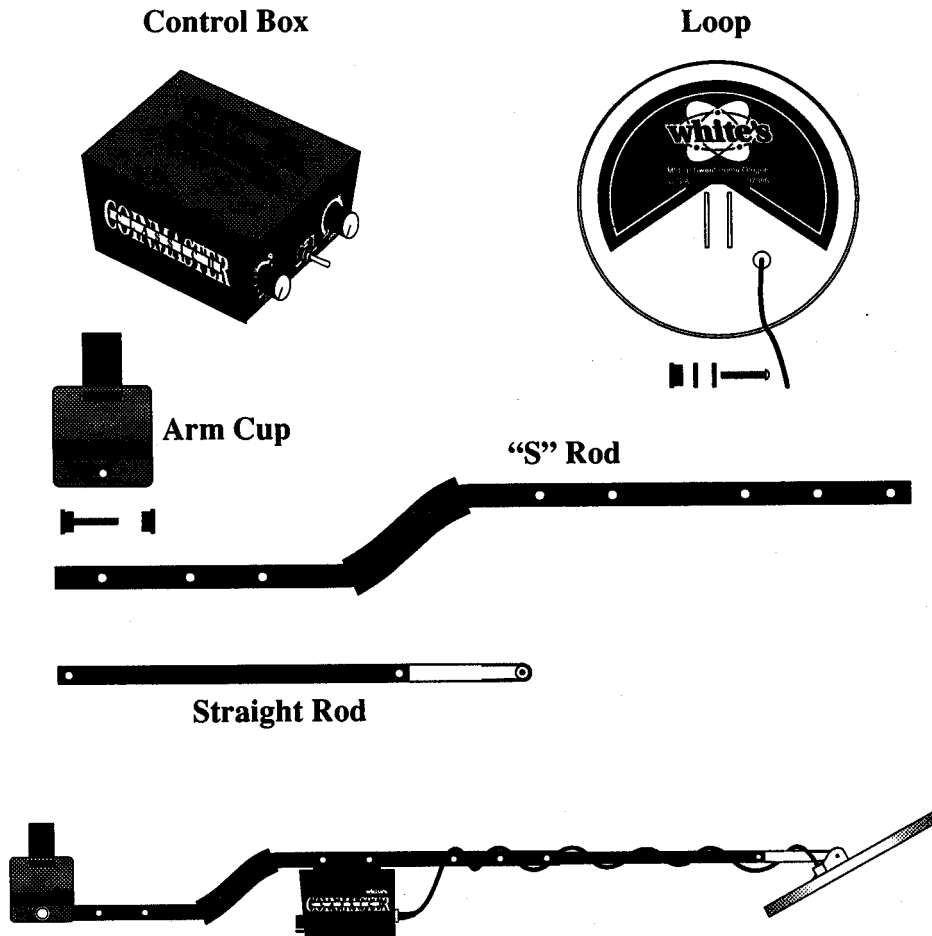

The Classic II comes partially assembled. The Straight Rod will need to be attached to the loop as shown (be sure and place the two rubber washers on the end of the Straight Rod as shown before sliding end onto the loop):

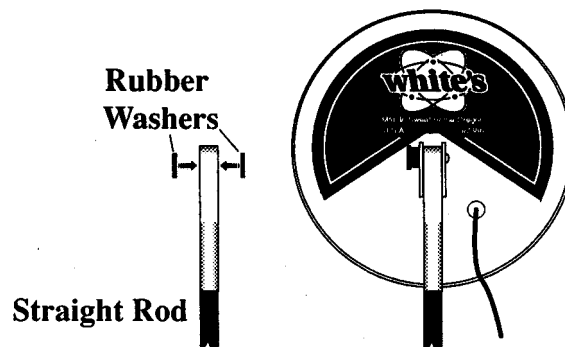

The Straight Rod connects to the "S" Rod by lining up the two pushbuttons on the Straight Rod with the two holes in the "S" Rod.

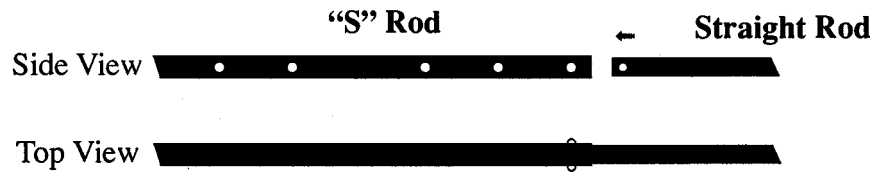

The control box snaps off and on the rod by compressing the two spring clip buttons on one side and pivoting the control box.

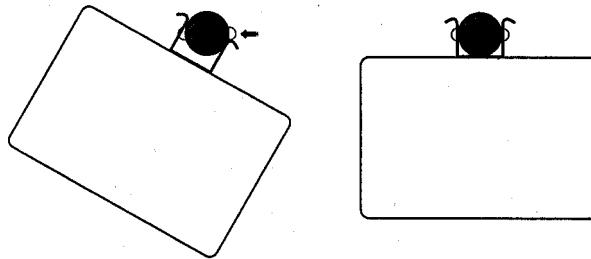

Optional control box mountings are available on the "S" Rod.

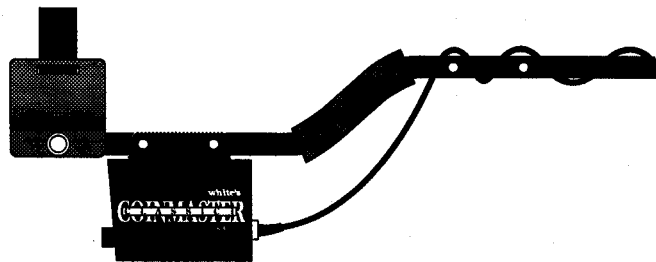

This model can also be worn as a hipmount simply by removing the control box from the "S" Rod, adjusting the length of cable wound around the rod, and weaving a belt through the slots on the control box.

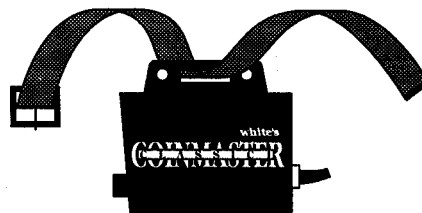

Batteries

The Classic II is powered by three TRANSISTOR 9 Volt batteries.

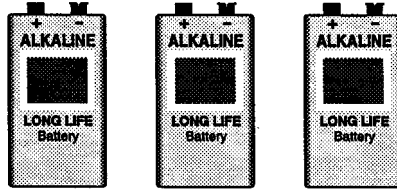

Open the battery compartment by grasping the black plastic plunger and pulling.
NOTE: The battery compartment door is located on the back of the control box opposite the control panel.

Once the door is removed, attach the battery leads to the batteries.

NOTE: They will fit one way. NOTE: One of the battery leads is different than the other two. It may be a different color or be marked in such a way as to identify it from the other two. This battery lead runs the audio (beep). When headphones are NOT used, this audio (beep) battery will become low (weak), before the other two. When headphones ARE used, the batteries may or may not discharge at the same rate. It is recommended that the batteries be rotated occasionally to achieve maximum battery life.

Alkaline 9 volt transistor batteries should last between 30 to 40 hours if rotated from battery lead to battery lead. Battery rotation is suggested as follows:

Battery Rotation Schedule

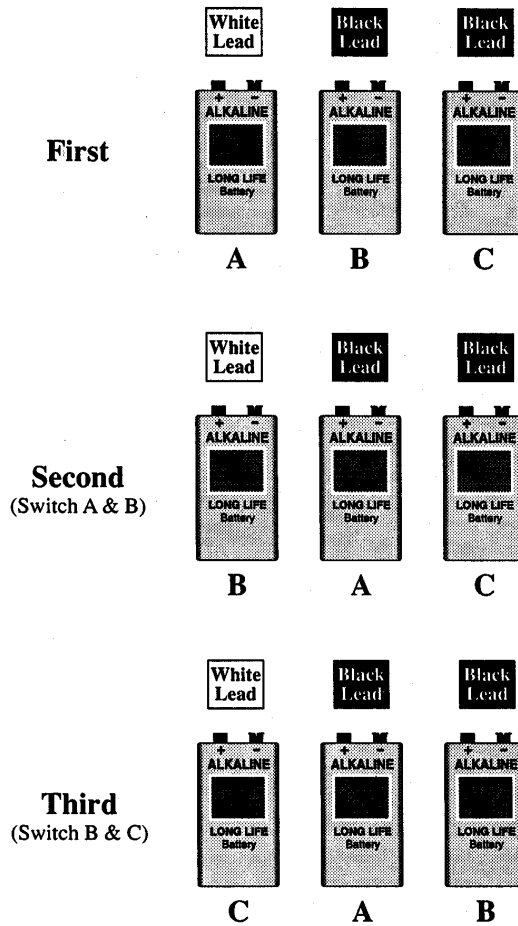

It is not necessary to reposition both black lead batteries to complete a rotation. Both black lead batteries run the same circuit thus moving one to the white lead and the white lead battery to the black lead completes a rotation.

Your instrument is designed to run on these batteries well below their normal voltages thus external battery testers will not accurately test whether the batteries need to be replaced.

- 1 If the volume (beep) seems to be getting weak (low), however the detector responds well to metal, rotate the battery positions.
2. If the volume (beep) is strong, however the detector doesn't respond well to metal, rotate the batteries or replace one or both non-audio batteries (black leads).
3. If the volume (beep) is weak, and the detector doesn't respond well to metal, replace all three batteries.

Operating Instructions

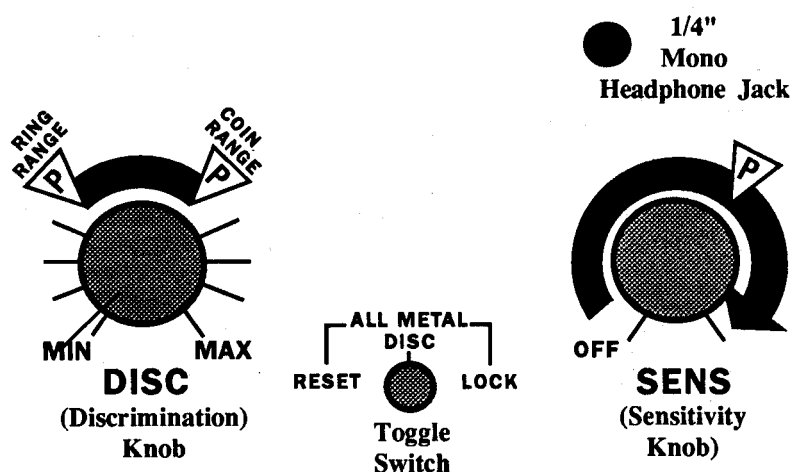

1. Once, fully assembled, set the **SENS** Knob to the **P** Preset position.
2. Place the **TOGGLE** switch on the **DISC** position.
3. The **DISC** Knob has two **P** positions.
 - a. The **RING RANGE P** is recommended. With the **DISC** Knob at this position, the detector will reject most iron and light foil, and respond to most valuables including jewellery.
 - b. The **COIN RANGE P** is optional. With the **DISC** Knob at this position, the detector will reject more junk including aluminium pull tabs. However, nickels and some jewellery will also be rejected.
 - c. If you are using the **RING RANGE P** and you feel you are digging too much junk, switch to the **COIN RANGE P**, or adjust to a spot between Coin & Ring Range that produces less junk.
 - d. When a metal is rejected, it produces a click or flutter sound. When accepted, a metal produces a smooth solid beep.
4. Sweep the loop close to the ground passing from side-to-side. Walk forward slowly while sweeping, and make sure each pass of the loop overlaps the last. Each pass of the loop from right to left should take approximately two seconds. If the loop is swept very, very slow, or the detector is stopped, the detector may not respond to metal.
5. At this point, it is a good idea to find an area free of metal to practice. Place a quarter or dime on the ground. Pass the loop over the target. Note: If you sweep the

loop over the coin, it is detected. If you stop the loop over the coin or sweep too slow, the instrument doesn't respond. Thus, loop movement is required for proper performance.

6. Place a large nail or steel bottle cap on the ground and pass the loop over them. Note the way the detector clicks or produces a flutter sound. Now pass the loop over a coin, and note the difference in sound. An operator will soon learn to ignore the clicks or flutters junk produces, and listen for the smooth beep coins and good metals produce.

7. Once a good beep has been located, pinpointing exactly where to dig can be completed several different ways.

a. "X" the area, and "eyeball" the center.

b. Hold the **TOGGLE** in the **RESET** position, then "X" the area and eyeball the center. Loudest beep indicates center.

c. Place the **TOGGLE** in **LOCK**, or hold in "Reset" position while holding the loop near the ground. "X" the area, and eyeball the center. Loudest beep indicates center. Be sure to switch toggle back to **DISC** before continuing.

8. When the **TOGGLE** is either held in the **RESET** position or in the **LOCK** position, this model responds to all types of metals regardless of the **DISC** Knob setting. It is a good idea to hold the loop near the ground when switching the **TOGGLE** in and out of **LOCK**.

Explanation of Controls ON/OFF SENS (Sensitivity)

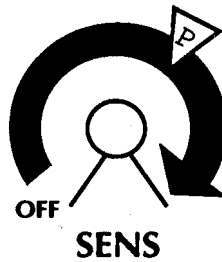

What does it do?

The SENS control turns the detector ON and OFF, and is used to select the (Sensitivity) or degree to which this instrument responds.

Why should I use it?

The P works well in most areas, however there are two reasons an operator may wish to change the sensitivity setting:

1. If when using this model with the **SENS** control at P it makes a lot of noise, beeping or clicking, when you sweep the loop, or continues even when the loop is away from the ground, the **SENS** control should be turned counter clockwise thus reducing the sensitivity, and allowing smooth stable operation.

2. If when operating this detector with the **SENS** control at P it works well, quiet and smooth, increasing the **SENS** control clockwise will increase sensitivity and detection depth, but may produce unstable audio responses.

Experience and personal preference will dictate how stable you prefer your instrument to perform. The **SENS** control allows for this adjustment.

Explanation of Controls DISC (discrimination)

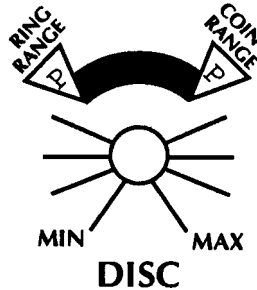

What does it do?

The **DISC** control selects the amount of rejection against junk metals. At **MIN** (minimum) most everything is detected at **MAX** (maximum) most junk is rejected.

Why would I use it?

The **RING RANGE P** rejects junk, and responds to most valuables including jewellery. This **RING RANGE** is recommended for most areas. If, however, you dig too much junk at this setting, increasing the **DISC** control to the **COIN RANGE P** will reject more junk. Some valuables including nickels, and some jewellery may also be rejected.

Again experience and personal preference will be a factor in selecting this setting. An operator must consider the likeliness of jewellery in the area to be searched, and how much digging of junk metals is acceptable in the area; and to the operator personally, how hard do you want to work the area.

If you want to find nickels and jewellery with this model, you are going to have to dig your share of the junk metals that respond similarly. See Advanced Options for some help on this subject.

Explanation of Controls Toggle Switch

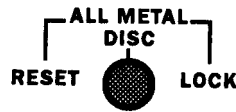

What does it do?

The **TOGGLE** allows an operator to switch between the detectors operating modes. **DISC** is the most commonly used mode as it rejects junk metals. **LOCK** is a mode which detects all types of metals, and is often used for pinpointing a metal's exact location. **RESET** readjusts and balances the circuit when the toggle is pushed to this position and released. If pushed and held in the reset position, the instrument responds just like the lock position.

Why would I use it?

If you're like most operators, you will search with the toggle in the **DISC** position to rule out some of the junk metals. Once a good metal is located, you could either #1 - push and hold the toggle in the **RESET** position and "X" the target to pinpoint its exact location, or #2 - push the toggle to **LOCK** and "X" the target to PinPoint its exact location. Push the toggle back to **DISC** before continuing to search. If you wish to search for metals such as iron or steel, leave the **TOGGLE** in **LOCK** so the instrument will respond to all types of metals.

Explanation of Controls Headphones

What does it do?

Headphones are available from your Dealer for your Classic II. They plug into the 1/4 inch jack on the face of the instrument where the knobs are located. This is a mono type jack; headphones need to be mono or have mono capabilities to work correctly. 8-16 Ohms are recommended.

Why would I use it?

Headphones do four things:

- 1) Increase battery life.
- 2) Increase an operator's ability to hear the detector.
- 3) Provide privacy to the operator.
- 4) Keeps the beeping noises from annoying less enthusiastic bystanders.

Headphones **are** recommended.

Search Methods

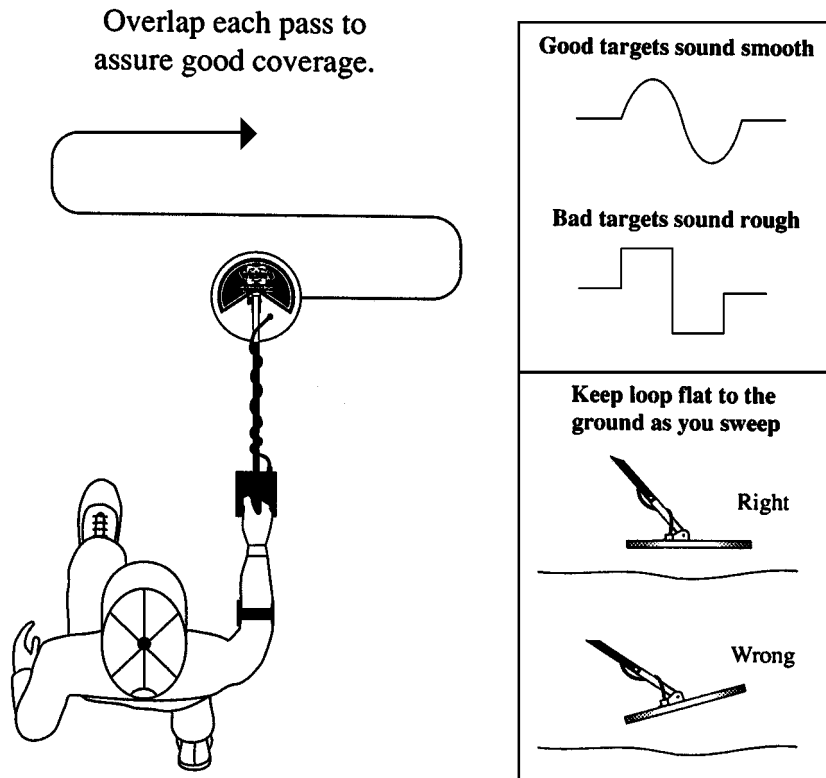

Because the loop of this model must be moving in order to respond to metal, the sweep of the loop is critical to performance. Sweep the loop close to the ground, keep it close and flat throughout the sweep. (See examples.)

If you have an area that has produced valuables, or has the potential for producing valuables, cover the area twice. First in one direction, then again at a 90 ° angle from the first.

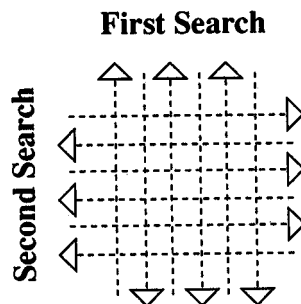

Once a good metal is located, "X" the area to pinpoint the target. Listen for the loudest beep as you sweep the loop, then stop and sweep in the other direction and listen for the loudest beep. The point where the two loudest beeps intersect is the center point of the target.

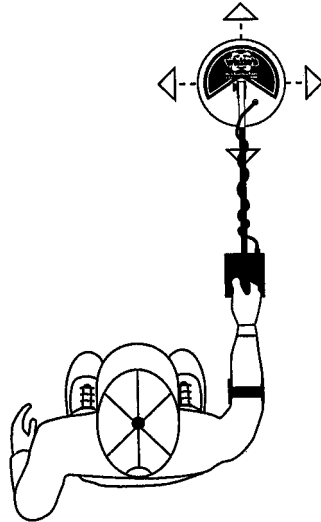

Proper Care of your Detector

CLEANING:

Both the loop and rod are waterproof, and can be cleaned with fresh water and a mild soap. After cleaning, dry the instrument thoroughly. **Caution:** Never raise the wet loop above the level of the instrument case. The instrument case is not waterproof, and water may run down the rod into the case damaging the electronic components.

WEATHER CONDITIONS:

Protect your detector from excessively cold weather. Freezing can damage the electronic components, the case and/or the battery. Excessive heat can also damage the instrument. Never leave it in the sun. It's best to lay it in the shade when not in use. If it's left in a car on a hot day, cover it to protect it from the direct rays of the sun, and then leave the windows slightly open, to permit ventilation. Your detector has been changed to resist light to moderate rain. Protection is required for heavy rain. (Use a plastic bag.) Avoid getting water in the Control Box.

SALTWATER:

Saltwater is very corrosive! After your detector has been exposed to saltwater, rinse the loop and rods in fresh water being careful not to let the loop rise higher than the level of the instrument case. Then wipe it with a cloth dampened with fresh water, and dry it thoroughly. Do not allow the main control box to get wet.

STORAGE:

If you plan to store your instrument for any length of time, unsnap the batteries and remove them from the instrument. Whenever your instrument is not in use, turn the ON/OFF **SENS** Knob all the way to the left until it clicks off.

ADDITIONAL PRECAUTIONS:

- a) Avoid dropping your detector.
- b) Do not use any lubricants on any part of your metal detector.
- c) Avoid sharp jars to the loop.
- d) Do not allow battery to corrode inside the instrument
- e) Do not alter or modify your instrument during its warranty period. Alterations will void the warranty.

SERVICE:

If ever in need of repairs, you may either contact the Dealer you purchased from, your nearest White's Service Center, or White's factory direct. Telephone toll-free 1-800-547-6911 for the Service Center for your area.

Advanced Operators/Dealers Ground Rejection

The ground rejection of the Classic II is factory preset at a level slightly positive of a ferrite mineral sample. This setting should provide good performance in average ground.

If you notice false targeting, and performance doesn't equal your expectations, the ground rejection may need to be adjusted for your area. Place the **TOGGLE** in the **LOCK** position, and lower the loop to the ground. If you notice target response 'beep' as the loop is abruptly lowered to and/or lifted from the ground, performance can be improved by readjusting the ground rejection.

Look at the bottom of the control box. Locate the "**GEB COVER**" correctly.

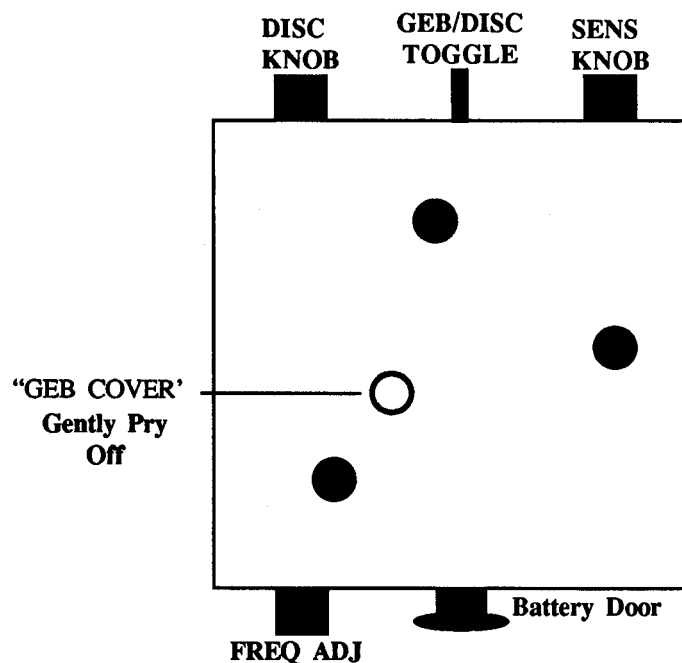

CAUTION: Do not tamper with the other three plastic parts on the bottom of the control box as these secure the circuit board. Use a small regular screwdriver to gently pry off the **GEB COVER**. Save the cover to put back on after adjustment.

Once the **GEB** cover is removed, look through the hole. You will see the small adjustment trimmer used to adjust ground rejection. Counter clockwise sets this model for higher ground mineral. Clockwise sets this model for lower ground mineral. When set properly, the loop can be abruptly lowered to, and lifted from, the ground with the **TOGGLE** in the **LOCK** position without a target response "beep".

The proper ground rejection setting provides good detection depth with a minimum of false targeting.

Advanced Operators/Dealers Discrimination

The discriminate control can be further labelled with more specific information which will aid in determining if a metal is junk such as a pull tab, or good such as jewellery.

To mark these settings you will need an ordinary United States nickel and an ordinary aluminium pull tab. You will also need an area free of metal which is representative of the ground you normally search (similar).

Bury the nickel about an inch in the ground. Use your instrument in the **DISC** mode. Sweep over the nickel and adjust the DI SC control. Note that if the DI SC control is too high, the nickel is rejected. Find the furthest position clockwise on the DI SC dial which detects the nickel with a good sound. Mark this point on the dial.

Now do the same thing with the pull tab, place it an inch in the ground, pass over it, and adjust the DI SC control. Note where it is rejected This time mark the furthest counter clockwise position on the DI SC dial that rejects the pull tab.

If you complete this correctly, you will now have two marks on your discriminate dial, one which is the highest point a nickel is accepted, and the other is the lowest point a pull tab is rejected.

You are now ready to search. Put the DI SC control at the nickel mark. Once a good target is heard, continue sweeping the loop over the target while turning the DI SC control clockwise. If the target starts being rejected before your pull tab mark chances are it's a nickel or jewellery. If it's not rejected until the pull tab mark, it's probably a pull tab. If its not rejected it is a good target.

Note: If the nickel and pull tab settings are very close to the same, get a different pull tab

Glossary of Terms.

Alkaline Battery: Type of non-rechargeable battery that can be purchased. It has the ability to sustain longer periods of current drain, and greater storage life than the carbon-zinc type batteries.

Control Box: Aluminium body of instrument (case).

Detect: Respond by "beep".

Discrimination: The ability to accept or reject (distinguish) metals of different characteristics, nails, bottle caps, coins, etc.

Good Metals: Metals determined by the position of the DI SC control to be acceptable. Desirable metals.

Ground: Dirt or the surface of the earth.

Ground Rejection: The cancellation of ground mineralization to ignore the masking effect ground minerals have over metals.

Indicate: Advice, proclaim, or point out.

Junk Targets: Metals determined to be trash or rejects, iron, foil, pull tabs, etc.

Max: The most or highest possible.

Metal: Metallic substances iron, foil, nickel, aluminium, gold, brass, lead, zinc, copper, silver, etc.

Mineral: Ferric oxide (iron) or other such non-organic substances naturally occurring.

Min: Minimum, the least possible.

Mode: An operation selection for specific operating characteristics.

Motion: Movement or sweep.

Performance: Efficiency, the manner in which an instrument responds.

Pinpoint: Finding the metals exact location with respect to the loops physical center.

Preset P: Control position determined to be ideal for average search conditions.

Reject: Discriminate, cancel response or effect.

Sensitivity: (SENS) Capacity or degree to which an instrument responds.

Stable: Ability of a metal detector to maintain smooth Predictable operation.

Sweep: Loop movement from side-to-side.

"X": cross the target from two different sides 90° from each other.

White's Electronics, Inc. Limited Warranty

If within two years (24 months) from the original date of purchase, your White's detector fails due to defects in either material or workmanship, White's will repair or replace at its option, all necessary parts without charge for parts or labor.

Simply return the complete detector to the Dealer where you purchased it, or to your nearest Authorized Service Center. The unit must be accompanied by a detailed explanation of the symptoms of the failure. You must provide proof of date-of-purchase before the unit is serviced.

This is a transferable manufacturer warranty, which covers the instrument two years from the original purchase date, regardless of the owner.

Items excluded from the warranty are non-rechargeable batteries, accessories that are not standard equipment, shipping / handling costs outside the continental USA, Special Delivery costs (Air Freight, Next Day, 2nd Day, Packaging Services, etc.) and all shipping / handling costs inside the continental USA 90 days after purchase.

White's registers your purchase only if the Sales Registration Card is filled out and returned to the factory address soon after original purchase for the purpose, of recording this information, and keeping you up-to-date regarding White's ongoing research & development.

The warranty does not cover damage caused by accident, misuse, neglect, alterations, modifications, unauthorized service, or prolonged exposure to corrosive compounds, including salt.

Duration of any implied warranty (e.g., merchantability and fitness for a particular purpose) shall not be longer than the stated warranty. Neither the manufacturer or the retailer shall be liable for any incidental or consequential damages. Some states however, do not allow the limitation on the length of implied warranties, or the exclusion of incidental or consequential damages. Therefore, the above limitations may not apply to you.

In addition, the stated warranty gives you specific legal rights, and you may have other rights, which vary from state-to-state.

The foregoing is the only warranty provided by White's as the manufacturer of your metal detector. Any "extended warranty" period beyond two years, which may be provided by a Dealer or other third party on your detector, may be without White's authority involvement and consent, and might not be honoured by White's.